

Portable ultrasonic flow measurement of gas

Portable instrument for non-invasive, quick ultrasonic flow measurement with clamp-on technology for all types of piping

Features

- Precise bi-directional and highly dynamic flow measurement with the non-invasive clamp-on technology
- High precision at fast and slow flow rates, high temperature and zero point stability
- Portable, easy-to-use flow transmitter with 2 flow channels, multiple inputs/outputs, an integrated data logger with a serial interface
- Water and dust-tight (IP65); resistant against oil, many liquids and dirt
- Li-Ion battery provides up to 25 hours of measurement operation
- Automatic loading of calibration data and transducer detection for a fast and easy set-up (less than 5 min), providing precise and long-term stable results
- User-friendly design
- Transducers available for a wide range of inner pipe diameters and fluid temperatures
- Probe for wall thickness measurement available
- Robust, water-tight (IP67) transport case with comprehensive accessories
- QuickFix for fast mounting of the flow transmitter in difficult conditions
- Including measurement of liquids

Applications

Designed for industrial use in harsh environments, in gas processing and natural gas extraction, chemical industry and in the petroleum industry. Practical applications:

- Measurement on natural gas pipelines and in natural gas storage installations
- Measurement of synthesized gas and injection gas
- Measurement for the gas supply industry
- Supervision of permanently installed meters, service and maintenance



FLUXUS G601 supported by handle

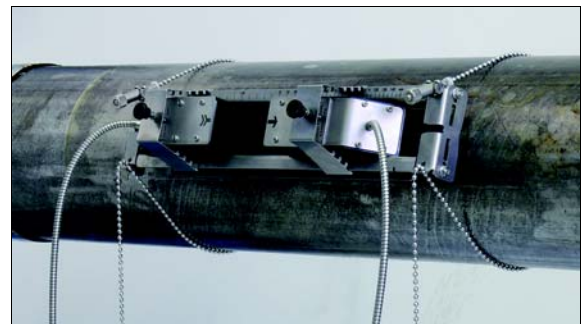

Measurement with transducers mounted with the portable Variofix VP



Measurement equipment in transport case

Table of contents

Function	3
Measurement principle	3
Calculation of volumetric flow rate	3
Number of sound paths	4
Typical measurement setup	5
Standard volumetric flow rate	5
Flow transmitter	6
Technical data	6
Dimensions	8
Standard scope of supply	9
Connection of adapters	10
Example for the equipment of a transport case	11
Transducers	12
Transducer selection	12
Transducer order code	15
Technical data	16
Transducer mounting fixture	21
Coupling materials for transducers	23
Damping mats (optional)	24
Connection systems	25
Transducer cable	25
Clamp-on temperature probe (optional)	26
Wall thickness measurement (optional)	28

Function

Measurement principle

In order to measure the flow of a fluid in a pipe, ultrasonic signals are used, employing the transit time difference principle. Ultrasonic signals are emitted by a transducer installed on the pipe and received by a second transducer. These signals are emitted alternately in the flow direction and against it.

As the fluid in which the signals propagate is flowing, the transit time of the ultrasonic signals in the flow direction is shorter than against the flow direction.

The transit time difference, Δt , is measured and allows the flowmeter to determine the average flow velocity along the propagation path of the ultrasonic signals. A flow profile correction is then performed in order to obtain the area averaged flow velocity, which is proportional to the volumetric flow rate.

Two integrated microprocessors control the entire measuring process. This allows the flowmeter to remove disturbance signals, and to check each received ultrasonic wave for its validity which reduces noise.

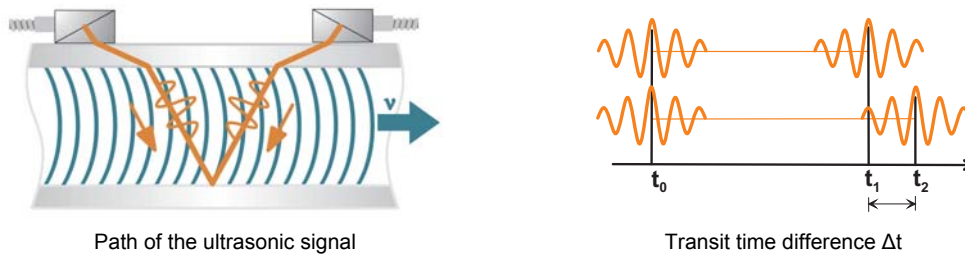

Calculation of volumetric flow rate

$$\dot{V} = k_{Re} \cdot A \cdot k_a \cdot \Delta t / (2 \cdot t_{fl})$$

where

- \dot{V} - volumetric flow rate
- k_{Re} - fluid mechanics calibration factor
- A - cross-sectional pipe area
- k_a - acoustical calibration factor
- Δt - transit time difference
- t_{fl} - transit time in the fluid

Number of sound paths

The number of sound paths is the number of transits of the ultrasonic signal through the fluid in the pipe. Depending on the number of sound paths, the following methods of installation exist:

- **reflection arrangement**

The number of sound paths is even. Both of the transducers are mounted on the same side of the pipe. Correct positioning of the transducers is easier.

- **diagonal arrangement**

The number of sound paths is odd. Both of the transducers are mounted on opposite sides of the pipe. In the case of a high signal attenuation by the fluid, pipe and coatings, diagonal arrangement with 1 sound path will be used.

The preferred method of installation depends on the application. While increasing the number of sound paths increases the accuracy of the measurement, signal attenuation increases as well. The optimum number of sound paths for the parameters of the application will be determined automatically by the transmitter.

As the transducers can be mounted with the transducer mounting fixture in reflection arrangement or diagonal arrangement, the number of sound paths can be adjusted optimally for the application.

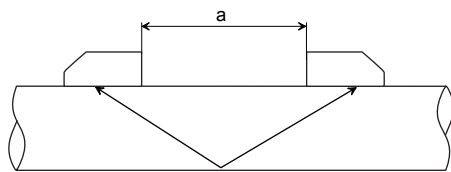

a - transducer distance

Reflection arrangement, number of sound paths: 2

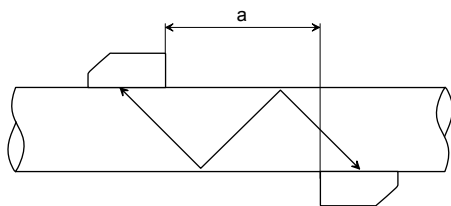

Diagonal arrangement, number of sound paths: 3

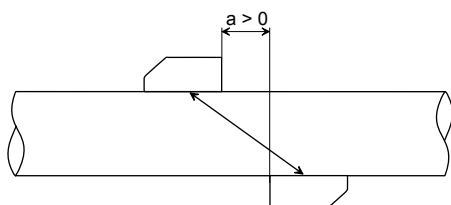

Diagonal arrangement, number of sound paths: 1

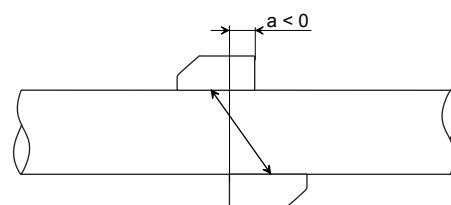

Diagonal arrangement, number of sound paths: 1, negative transducer distance

Typical measurement setup

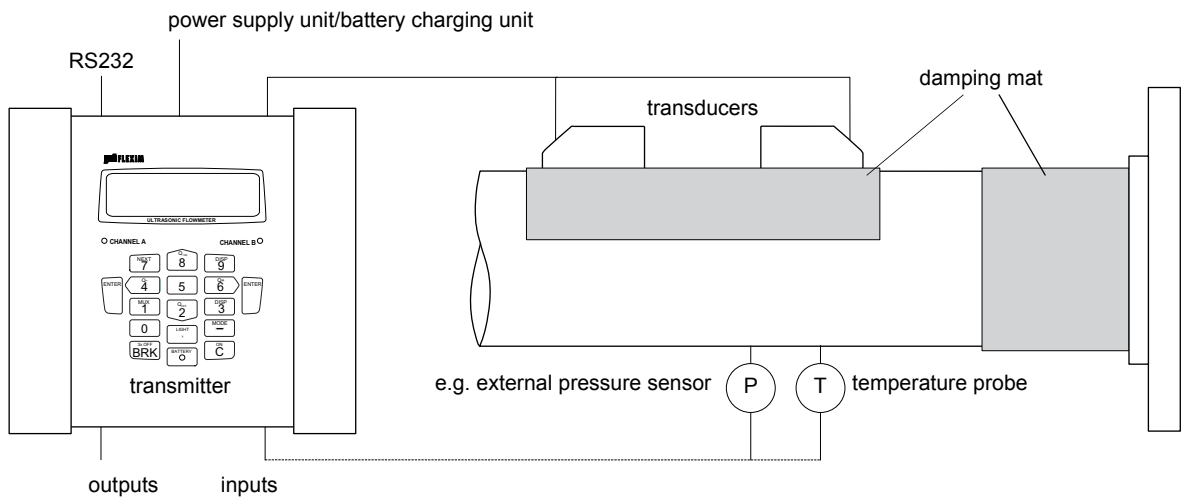

Example of a reflection arrangement with connection of the inputs to an external process pressure and process temperature measurement for standard volumetric flow rate calculation

Standard volumetric flow rate

The standard volumetric flow rate can be selected as physical quantity to be measured. It will be calculated internally by:

$$\dot{V}_N = \dot{V} \cdot p/p_N \cdot T_N/T \cdot 1/K$$

where

- \dot{V}_N - standard volumetric flow rate
- \dot{V} - operating volumetric flow rate
- p_N - standard pressure (absolute value)
- p - operating pressure (absolute value)
- T_N - standard temperature in K
- T - operating temperature in K
- K - compressibility coefficient of the gas: ratio of the compressibility factors of the gas at operating conditions and at standard conditions Z/Z_N

The operational pressure p and the operational temperature T of the fluid will be entered directly as fixed values into the transmitter.

or:

If inputs are installed (optional), pressure and temperature can be measured by the customer and fed in the transmitter.

The gas compressibility coefficient K of the gas is entered in the transmitter:

- as fixed value or
- as approximation according to e.g. AGA8 or GERG

Flow transmitter

Technical data

FLUXUS	G601
design	portable
	
measurement	
measurement principle	transit time difference correlation principle
flow velocity	0.01...35 m/s, depending on pipe diameter
repeatability	0.15 % of reading ± 0.01 m/s
fluid	all acoustically conductive gases, e.g. nitrogen, air, oxygen, hydrogen, argon, helium, ethylene, propane
temperature compensation	corresponding to the recommendations in ANSI/ASME MFC-5.1-2011
accuracy	
volumetric flow rate	$\pm 1...3$ % of reading ± 0.01 m/s depending on application ± 0.5 % of reading ± 0.01 m/s with field calibration
flow transmitter	
power supply	100...230 V/50...60 Hz (power supply unit) 10.5...15 V DC (socket at transmitter) integrated battery
integrated battery - operating time	Li-Ion, 7.2 V/6.2 Ah > 14 h (without outputs, inputs and backlight) > 25 h (1 measuring channel, ambient temperature > 10 °C, without outputs, inputs and backlight)
power consumption	< 6 W (with outputs, inputs and backlight)
number of flow measuring channels	2
damping	0...100 s, adjustable
measuring cycle (1 channel)	100...1000 Hz
response time	1 s (1 channel), option: 70 ms
housing material	PA, TPE, AutoTex, stainless steel
degree of protection according to IEC/EN 60529	IP65
dimensions	see dimensional drawing
weight	2.1 kg
fixation	QuickFix pipe mounting fixture
ambient temperature	-10...+60 °C
display	2 x 16 characters, dot matrix, backlight
menu language	English, German, French, Dutch, Spanish
measuring functions	
physical quantities	operating volumetric flow rate, standard volumetric flow rate, mass flow rate, flow velocity
totalizer	volume, mass
calculation functions	average, difference, sum
diagnostic functions	sound speed, signal amplitude, SNR, SCNR, standard deviation of amplitudes and transit times

FLUXUS	G601
communication interfaces	
diagnostic interfaces	- RS232 - USB (with adapter)
process interfaces (optional)	- Modbus RTU
serial data kit	
software	- FluxDiagReader: download of measured values and parameters, graphical presentation - FluxDiag (optional): download of measurement data, graphical presentation, report generation - FluxSubstanceLoader: upload of fluid data sets
cable	RS232
adapter	RS232 - USB
data logger	
loggable values	all physical quantities, totalized values and diagnostic values
capacity	> 100 000 measured values
transport case	
dimensions	500 x 400 x 190 mm
outputs	
	The outputs are galvanically isolated from the transmitter.
number	see standard scope of supply on page 9, max. on request
accessories	output adapter (if number of outputs > 4)
current output	
range	0/4...20 mA
accuracy	0.1 % of reading $\pm 15 \mu\text{A}$
active output	$R_{\text{ext}} < 750 \Omega$ ($U_{\text{int}} = 24 \text{ V DC}$)
passive output	$U_{\text{ext}} = 4...16 \text{ V}$, depending on R_{ext} $R_{\text{ext}} < 500 \Omega$
frequency output	
range	0...5 kHz
open collector	24 V/4 mA
binary output	
optorelay	26 V/100 mA
binary output as alarm output - functions	limit, change of flow direction or error
binary output as pulse output - pulse value - pulse width	mainly for totalizing 0.01...1000 units 1...1000 ms
inputs	
	The inputs are galvanically isolated from the transmitter.
number	see standard scope of supply on page 9, max. 4
accessories	input adapter (if number of inputs > 2)
temperature input	
type	Pt100/Pt1000
connection	4-wire
range	-150...+560 °C
resolution	0.01 K
accuracy	$\pm 0.01 \%$ of reading $\pm 0.03 \text{ K}$
current input	
accuracy	0.1 % of reading $\pm 10 \mu\text{A}$
passive input	$R_{\text{int}} = 50 \Omega$, $P_{\text{int}} < 0.3 \text{ W}$
- range	-20...+20 mA
voltage input	
range	0...1 V
accuracy	0.1 % of reading $\pm 1 \text{ mV}$
internal resistance	$R_{\text{int}} = 1 \text{ M}\Omega$

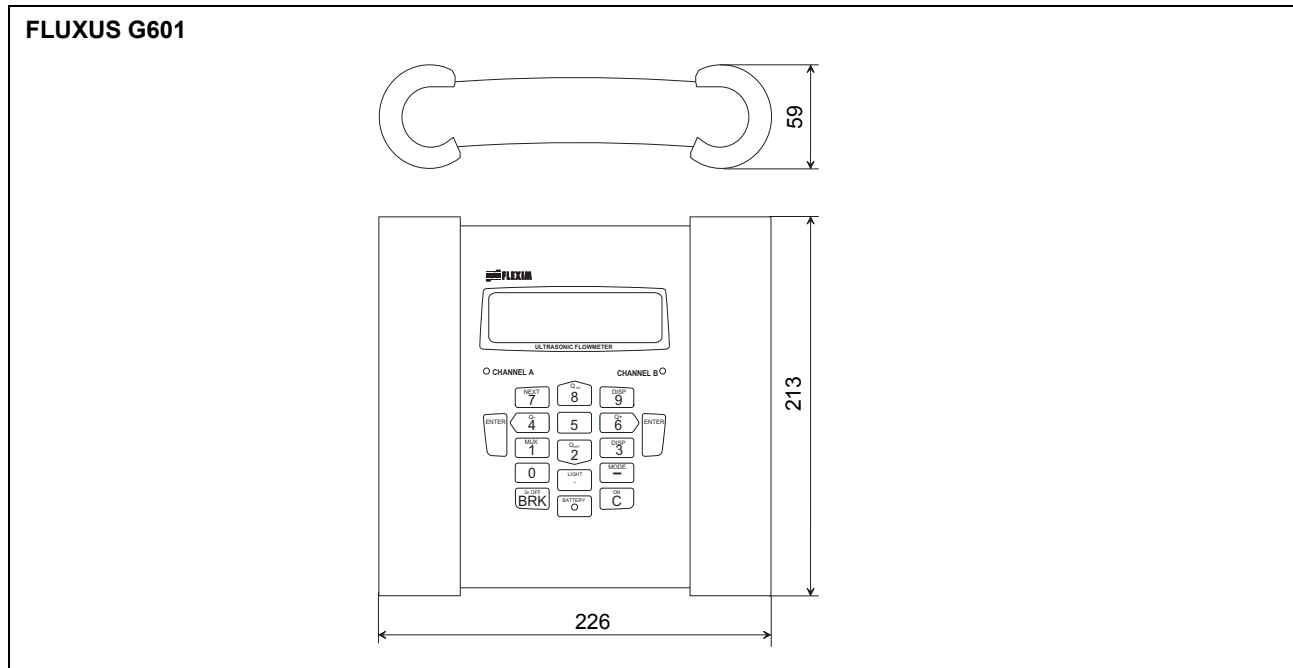

For the technical data in the flow measurement of liquids mode see Technical specification TSFLUXUS_F601Vx-x.

Dimensions

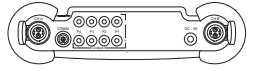

in mm

Standard scope of supply

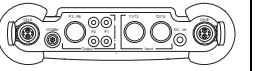
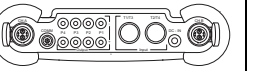
	G601 Standard		G601 Extended Standard		G601 Multi-functional		G601 CA-Energy	
application	flow measurement on gas						flow measurement on compressed air, industrial gases and liquids	
	2 independent measuring channels							
	calculation of standard volumetric flow rate	calculation of standard volumetric flow rate, with optional use of current measured pressure and temperature values						
			simultaneous monitoring of flow and energy flow		simultaneous monitoring of 2 energy flows		liquids: integrated heat flow computer for monitoring of energy flows	
outputs								
passive current output	2	2	2	2	2	2	2	2
binary output	2	1	1	1	2	2	2	1
frequency output	-	-	1	-	1	0	-	-
Modbus	-	x	-	x	-	x	-	x
inputs								
temperature input	-	-	-	-	1	1	2	2
passive current input	-	-	2	2	2	2	2	2
voltage input	-	-	-	-	1	1	-	-
accessories								
transport case	x	x	x	x	x	x	x	x
power supply unit, mains cable	x	x	x	x	x	x	x	x
battery	x	x	x	x	x	x	x	x
output adapter	-	-	-	-	x	x	-	-
input adapter	-	-	2	2	2	2	2	2
adapter for voltage and current inputs	-	-	-	-	3	3	2	2
QuickFix pipe mounting fixture for transmitter	x	x	x	x	x	x	x	x
serial data kit	x	x	x	x	x	x	x	x
measuring tape	x	x	x	x	x	x	x	x
wall thickness probe	-	-	-	-	x	x	x	x
user manual, Quick start guide	x	x	x	x	x	x	x	x
connector board at the upper side of the transmitter								

Connection of adapters

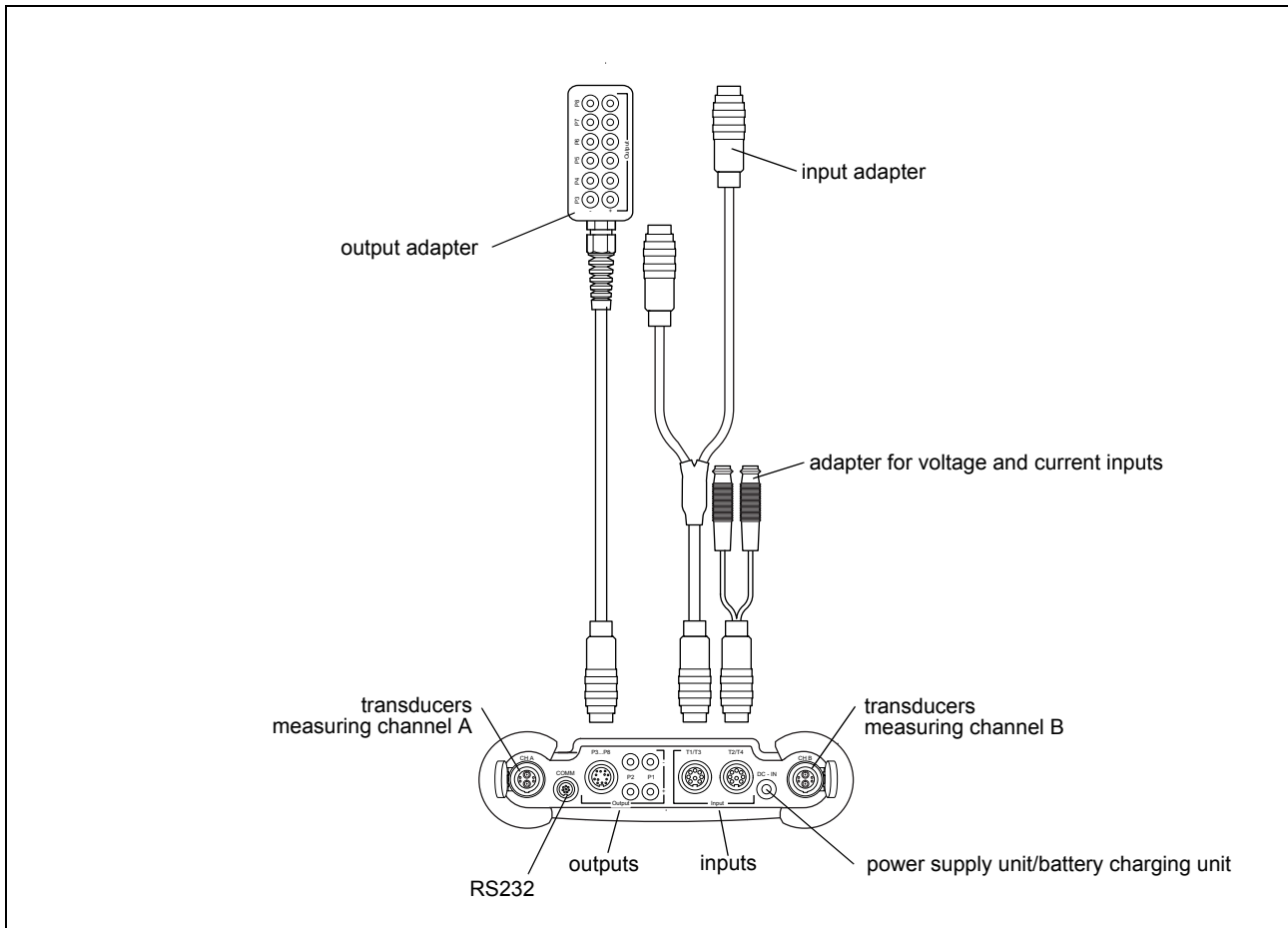

Example for the equipment of a transport case



Transducers

Transducer selection

Step 1a

Select a Lamb wave transducer:

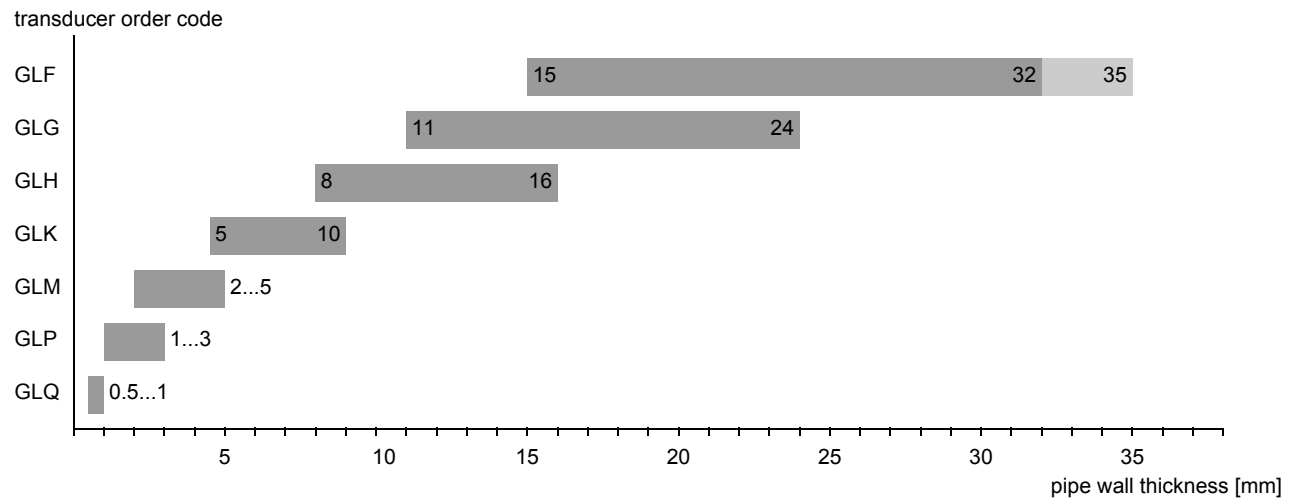

Step 1b

If the pipe wall thickness is not in the range of the Lamb wave transducers, select a shear wave transducer:

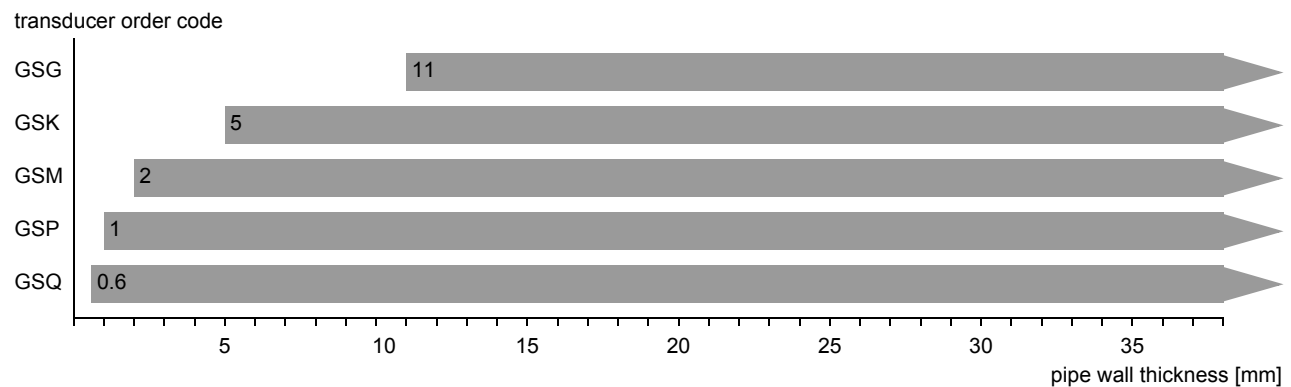

■ recommended ■ possible

Step 2

inner pipe diameter d dependent on the flow velocity v of the fluid in the pipe

The transducers are selected from the characteristics (see next page). Lamb wave transducers are selected from the left column, shear wave transducers from the right column.

Lamb wave transducers: If the values d and v are not in the range, the diagonal arrangement with 1 sound path may be used, i.e. the same characteristics can be used with doubling the inner pipe diameter. If the values are still not in the range, shear waves transducers regarding the pipe wall thickness have to be selected in step 1b.

Lamb wave transducer¹

shear wave transducer¹

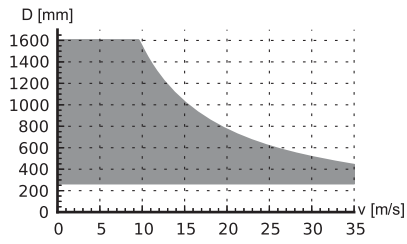

GLF

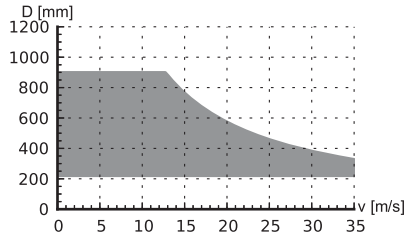

GLG

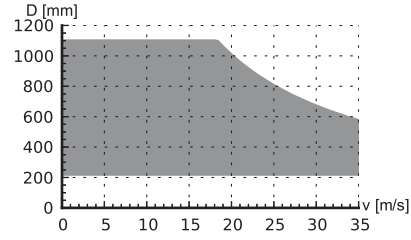

GSG

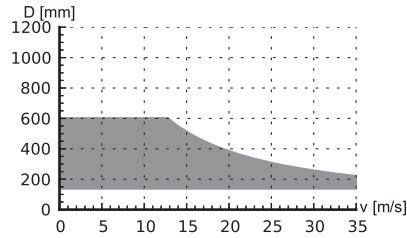

GLH

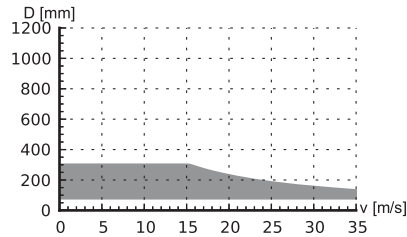

GLK

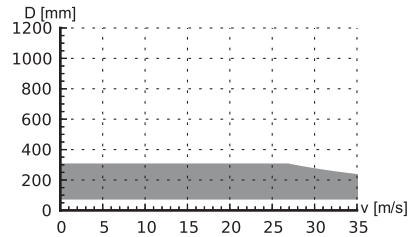

GSK

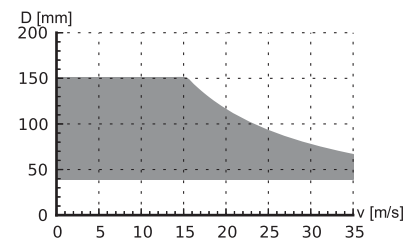

GLM

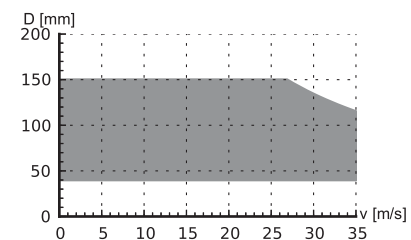

GSM

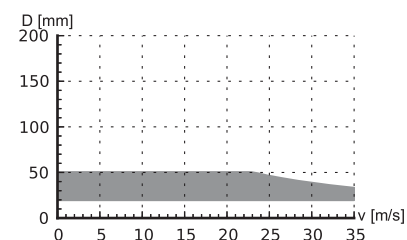

GLP

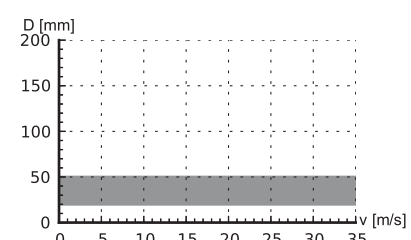

GSP

¹ inner pipe diameter and max. flow velocity for a typical application with natural gas, nitrogen, oxygen in reflection arrangement with 2 sound paths (Lamb wave transducers)/1 sound path (shear wave transducers)

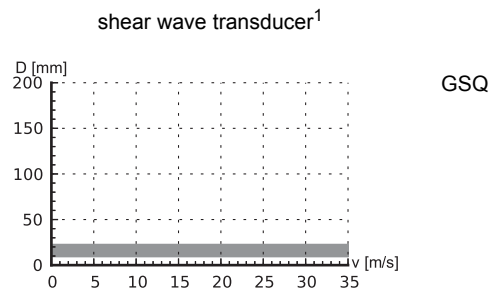
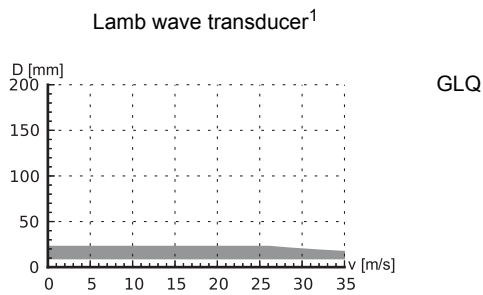

¹ inner pipe diameter and max. flow velocity for a typical application with natural gas, nitrogen, oxygen in reflection arrangement with 2 sound paths (Lamb wave transducers)/1 sound path (shear wave transducers)

Step 3

min. fluid pressure

Lamb wave transducer			
transducer order code	fluid pressure ¹ [bar]		
	metal pipe		plastic pipe
	min.	min. extended	min.
GLF	15	10	1
GLG	15	10	1
GLH	15	10	1
GLK	15 (d > 120 mm) 10 (d < 120 mm)	10 (d > 120 mm) 3 (d < 120 mm)	1
GLM	10 (d > 60 mm) 5 (d < 60 mm)	3 (d < 60 mm)	1
GLP	10 (d > 35 mm) 5 (d < 35 mm)	3 (d < 35 mm)	1
GLQ	10 (d > 15 mm) 5 (d < 15 mm)	3 (d < 15 mm)	1

shear wave transducer			
transducer order code	fluid pressure ¹ [bar]		
	metal pipe		plastic pipe
	min.	min. extended	min.
GSG	30	20	1
GSK	30	20	1
GSM	30	20	1
GSP	30	20	1
GSQ	30	20	1

¹ depending on application, typical absolute value for natural gas, nitrogen, compressed air

d - inner pipe diameter

Example

step					
1	pipe wall thickness selected transducer	mm	14.3 GLG or GLH	8.6 GLH or GLK	38 GS
2	inner pipe diameter max. flow velocity selected transducer	mm m/s	581 15 GLG	96.8 30 GLK	143 30 GSK
3	min. fluid pressure selected transducer	bar	20 GLG	15 GLK	40 GSK

Step 4

for the characters 4...11 of the transducer order code (ambient temperature, explosion protection, connection system, extension cable) see page 15

Step 5

for the technical data of the selected transducer see page 16 et seqq.

Transducer order code

1, 2	3	4	5, 6	7, 8	9...11	no. of character		
transducer	transducer frequency	-	ambient temperature	explosion protection	connection system	-	extension cable	description
GL								set of ultrasonic flow transducers for gas measurement, Lamb wave
GS								set of ultrasonic flow transducers for gas measurement, shear wave
	F							0.15 MHz (Lamb wave only)
	G							0.2 MHz
	H							0.3 MHz (Lamb wave only)
	K							0.5 MHz
	M							1 MHz
	P							2 MHz
	Q							4 MHz
			N					normal temperature range
			E					extended temperature range (FSM, FSP, FSQ)
				NN				not explosion proof
					NL			with Lemo connector
						XXX		cable length in m, for max. length of extension cable see page 25
example								
GL	K	-	N	NN	NL	-	000	Lamb wave transducer 0.5 MHz, normal temperature range, connection system NL with Lemo connector
		-				-		

Technical data

Shear wave transducers

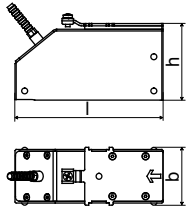
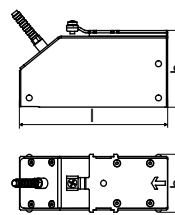
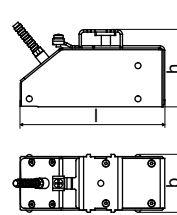
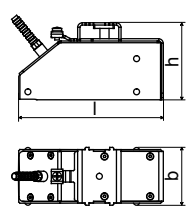
technical type		GDG1NZ7	GLG1NZ7	GDK1NZ7	GLK1NZ7
order code		GSG-NNNNL	GSG-NNNNL/LC	GSK-NNNNL	GSK-NNNNL/LC
transducer frequency	MHz	0.2	0.2	0.5	0.5
fluid pressure¹					
min. extended min.	bar bar	metal pipe: 20 metal pipe: 30 plastic pipe: 1		metal pipe: 20 metal pipe: 30 plastic pipe: 1	
inner pipe diameter d²					
min. extended	mm	180	180	60	60
min. recommended	mm	220	220	80	80
max. recommended	mm	900	900	300	300
max. extended	mm	1100	1100	360	360
pipe wall thickness					
min.	mm	11	11	5	5
material					
housing		PEEK with stainless steel cap 304 (1.4301)	PEEK with stainless steel cap 304 (1.4301)	PEEK with stainless steel cap 304 (1.4301)	PEEK with stainless steel cap 304 (1.4301)
contact surface		PEEK	PEEK	PEEK	PEEK
degree of protection according to IEC/EN 60529		IP67	IP67	IP67	IP67
transducer cable					
type		1699	1699	1699	1699
length	m	5	9	5	9
dimensions					
length l	mm	129.5	129.5	126.5	126.5
width b	mm	51	51	51	51
height h	mm	67	67	67.5	67.5
dimensional drawing					
ambient temperature					
min.	°C	-40	-40	-40	-40
max.	°C	+130	+130	+130	+130
temperature compensation		x	x	x	x

¹ depending on application, typical absolute value for natural gas, nitrogen, compressed air

² shear wave transducer:

typical values for natural gas, nitrogen, oxygen, pipe diameters for other fluids on request

inner pipe diameter max. recommended/max. extended: in reflection arrangement and for a flow velocity of 15 m/s

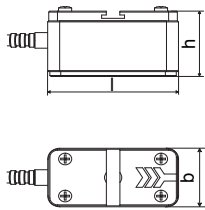
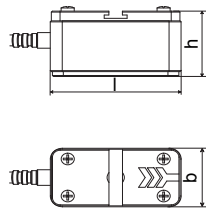
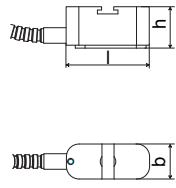
technical type		GDM1NZ7	GDP1NZ7	GDQ1NZ7
order code		GSM-NNNNL	GSP-NNNNL	GSQ-NNNNL
transducer frequency	MHz	1	2	4
fluid pressure¹				
min. extended	bar	metal pipe: 20	metal pipe: 20	metal pipe: 20
min.	bar	metal pipe: 30 plastic pipe: 1	metal pipe: 30 plastic pipe: 1	metal pipe: 30 plastic pipe: 1
inner pipe diameter d²				
min. extended	mm	30	15	7
min. recommended	mm	40	20	10
max. recommended	mm	150	50	22
max. extended	mm	180	60	30
pipe wall thickness				
min.	mm	2	1	0.6
material				
housing		stainless steel 304 (1.4301)	stainless steel 304 (1.4301)	stainless steel 304 (1.4301)
contact surface		PEEK	PEEK	PEEK
degree of protection according to IEC/EN 60529		IP67	IP67	IP67
transducer cable				
type		1699	1699	1699
length	m	4	4	3
dimensions				
length l	mm	60	60	42.5
width b	mm	30	30	18
height h	mm	33.5	33.5	21.5
dimensional drawing				
ambient temperature				
min.	°C	-40	-40	-40
max.	°C	+130	+130	+130
temperature compensation		x	x	x

¹ depending on application, typical absolute value for natural gas, nitrogen, compressed air

² shear wave transducer:

typical values for natural gas, nitrogen, oxygen, pipe diameters for other fluids on request

inner pipe diameter max. recommended/max. extended: in reflection arrangement and for a flow velocity of 15 m/s

Shear wave transducers (extended temperature range)

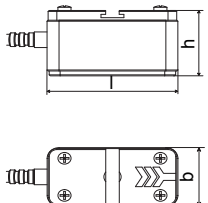
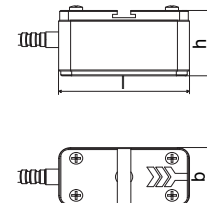
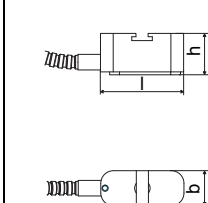
technical type		GDM1EZ7	GDP1EZ7	GDQ1EZ7
order code		GSM-ENNNL	GSP-ENNNL	GSQ-ENNNL
transducer frequency	MHz	1	2	4
fluid pressure¹				
min. extended min.	bar bar	metal pipe: 20 metal pipe: 30 plastic pipe: 1	metal pipe: 20 metal pipe: 30 plastic pipe: 1	metal pipe: 20 metal pipe: 30 plastic pipe: 1
inner pipe diameter d²				
min. extended	mm	30	15	7
min. recommended	mm	40	20	10
max. recommended	mm	150	50	22
max. extended	mm	180	60	30
pipe wall thickness				
min.	mm	2	1	0.6
material				
housing		stainless steel 304 (1.4301)	stainless steel 304 (1.4301)	stainless steel 304 (1.4301)
contact surface		Sintimid	Sintimid	Sintimid
degree of protection according to IEC/EN 60529		IP65	IP65	IP65
transducer cable				
type		1699	1699	1699
length	m	4	4	3
dimensions				
length l	mm	60	60	42.5
width b	mm	30	30	18
height h	mm	33.5	33.5	21.5
dimensional drawing				
weight (without cable)	kg	0.042 kg	0.042 kg	0.011 kg
ambient temperature				
min.	°C	-30	-30	-30
max.	°C	+200	+200	+200
temperature compensation		x	x	x

¹ depending on application, typical absolute value for natural gas, nitrogen, compressed air

² shear wave transducer:
 typical values for natural gas, nitrogen, oxygen, pipe diameters for other fluids on request
 inner pipe diameter max. recommended/max. extended: in reflection arrangement and for a flow velocity of 15 m/s

Lamb Wave Transducers

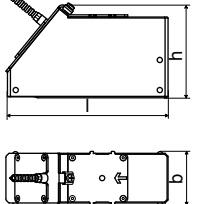
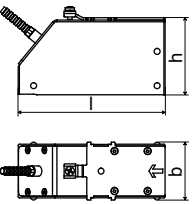
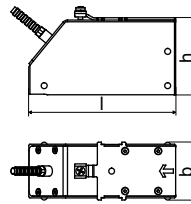
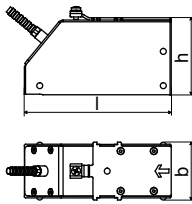
technical type		GRF1NC3	GRG1NC3	GRH1NC3	GRK1NC3
order code		GLF-NNNNL	GLG-NNNNL	GLH-NNNNL	GLK-NNNNL
transducer frequency		MHz 0.15	0.2	0.3	0.5
fluid pressure¹					
min. extended	bar	metal pipe: 10	metal pipe: 10	metal pipe: 10	metal pipe: 10 (d > 120 mm) 3 (d < 120 mm)
min.	bar	metal pipe: 15 plastic pipe: 1	metal pipe: 15 plastic pipe: 1	metal pipe: 15 plastic pipe: 1	metal pipe: 15 (d > 120 mm) 10 (d < 120 mm) plastic pipe: 1
inner pipe diameter d²					
min. extended	mm	220	180	110	60
min. recommended	mm	270	220	140	80
max. recommended	mm	1200	900	600	300
max. extended	mm	1600	1400	1000	360
pipe wall thickness					
min.	mm	15	11	8	5
max.	mm	32	24	16	10
max. extended	mm	35	-	-	-
material					
housing		PPSU with stainless steel cap 316Ti (1.4571)	PPSU with stainless steel cap 304 (1.4301)	PPSU with stainless steel cap 304 (1.4301)	PPSU with stainless steel cap 304 (1.4301)
contact surface		PPSU	PPSU	PPSU	PPSU
degree of protection according to IEC/EN 60529		IP65	IP65	IP65	IP65
transducer cable					
type		1699	1699	1699	1699
length	m	5	5	5	5
dimensions					
length l	mm	163	128.5	128.5	128.5
width b	mm	54	51	51	51
height h	mm	91.3	67.5	67.5	67.5
dimensional drawing					
ambient temperature					
min.	°C	-40	-40	-40	-40
max.	°C	+170	+170	+170	+170
temperature compensation		x	x	x	x

¹ depending on application, typical absolute value for natural gas, nitrogen, compressed air

² Lamb wave transducer:
 typical values for natural gas, nitrogen, oxygen, pipe diameters for other fluids on request
 inner pipe diameter max. recommended: in reflection arrangement (diagonal arrangement) and for a flow velocity of 15 m/s (30 m/s)
 inner pipe diameter max. extended: in reflection arrangement (diagonal arrangement) and for a flow velocity of 12 m/s (25 m/s)

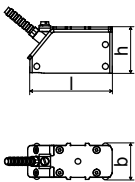
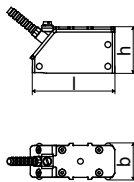
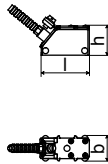
technical type		GRM1NC3	GRP1NC3	GRQ1NC3
order code		GLM-NNNNL	GLP-NNNNL	GLQ-NNNNL
transducer frequency	MHz	1	2	4
fluid pressure¹				
min. extended	bar	metal pipe: 3 (d < 60 mm)	metal pipe: 3 (d < 35 mm)	metal pipe: 3 (d < 15 mm)
min.	bar	metal pipe: 10 (d > 60 mm) 5 (d < 60 mm) plastic pipe: 1	metal pipe: 10 (d > 35 mm) 5 (d < 35 mm) plastic pipe: 1	metal pipe: 10 (d > 15 mm) 5 (d < 15 mm) plastic pipe: 1
inner pipe diameter d²				
min. extended	mm	30	15	7
min. recommended	mm	40	20	10
max. recommended	mm	150	50	22
max. extended	mm	180	60	30
pipe wall thickness				
min.	mm	2	1	0.5
max.	mm	5	3	1
max. extended	mm	-	-	-
material				
housing		PPSU with stainless steel cap 304 (1.4301)	PPSU with stainless steel cap 304 (1.4301)	PPSU with stainless steel cap 304 (1.4301)
contact surface		PPSU	PPSU	PPSU
degree of protection according to IEC/EN 60529		IP65	IP65	IP65
transducer cable				
type		1699	1699	1699
length	m	4	4	3
dimensions				
length l	mm	74	74	42
width b	mm	32	32	22
height h	mm	40.5	40.5	25.5
dimensional drawing				
ambient temperature				
min.	°C	-40	-40	-40
max.	°C	+170	+170	+170
temperature compensation		x	x	x

¹ depending on application, typical absolute value for natural gas, nitrogen, compressed air

² Lamb wave transducer:

typical values for natural gas, nitrogen, oxygen, pipe diameters for other fluids on request

inner pipe diameter max. recommended: in reflection arrangement (diagonal arrangement) and for a flow velocity of 15 m/s (30 m/s)

inner pipe diameter max. extended: in reflection arrangement (diagonal arrangement) and for a flow velocity of 12 m/s (25 m/s)

Transducer mounting fixture

Order code

1, 2	3	4	5	6	7...9	10, 11	no. of character			
transducer mounting fixture	transducer	-	measurement arrangement	size	-	fixation	outer pipe diameter	/	option	description
VP										portable Variofix
TB										tension belts
	A									all transducers
			D							reflection arrangement or diagonal arrangement
			R							reflection arrangement
				S						small
				M						medium
						C				chains
						G				tension belts
						N				without fixation
							055			10...550 mm
							150			50...1500 mm
							210			50...2100 mm
example										
VP	A	-	D	M	-	C	055			portable Variofix and chains
		-			-			/		

portable Variofix VP and chains

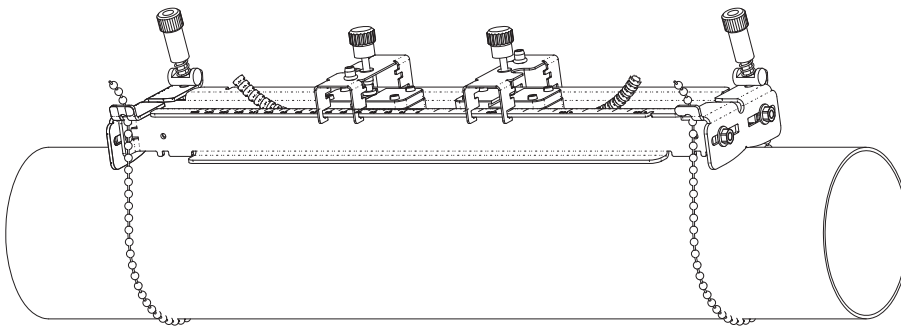

material: stainless steel 304 (1.4301), 301 (1.4310), 303 (1.4305)
 dimensions: 414 x 94 x 76 mm
 chain length: 2 m

portable Variofix VP and magnet (optional)

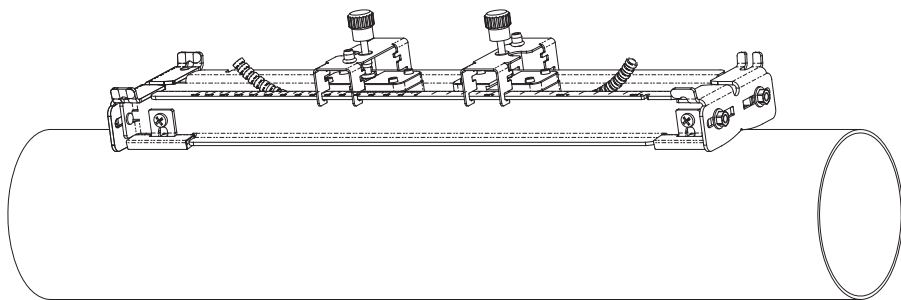

material: stainless steel 304 (1.4301), 301 (1.4310), 303 (1.4305)
 dimensions: 414 x 94 x 40 mm

portable Variofix VP and tension belts

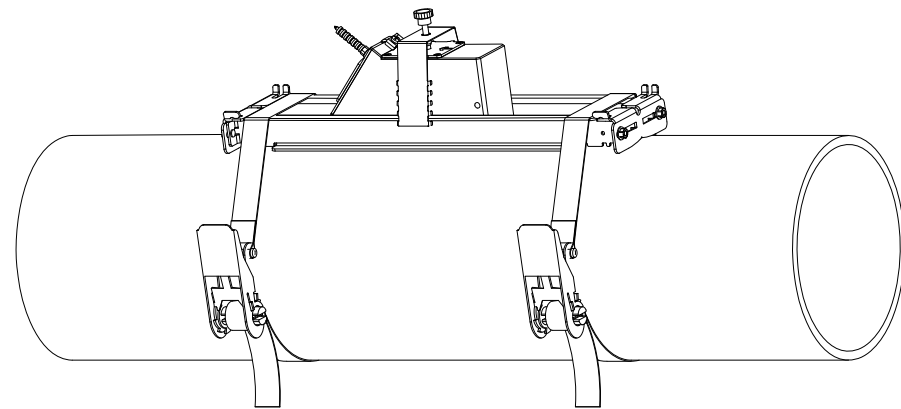

tension belts TB

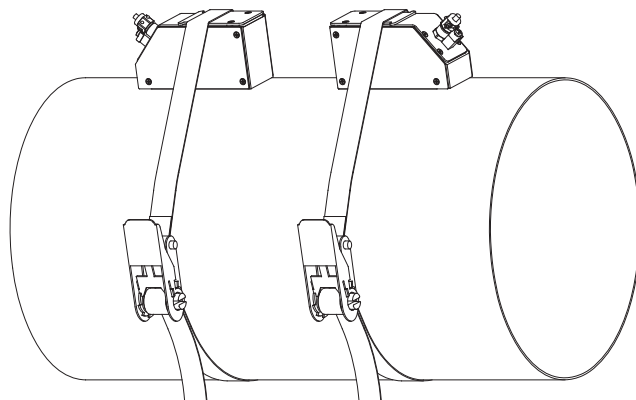

material: steel, powder coated and textile tension belt
 length: 5/7 m

ambient temperature: max. 60 °C
 outer pipe diameter: max. 1500/2100 mm

Coupling materials for transducers

normal temperature range (4th character of transducer order code = N)		extended temperature range (4th character of transducer order code = E)	
< 100 °C	< 170 °C	< 150 °C	< 200 °C
coupling compound type N	coupling compound type E	coupling compound type E	coupling compound type E or H

Technical data

type	ambient temperature °C	material
coupling compound type N	-30...+130	mineral grease paste
coupling compound type E	-30...+200	silicone paste
coupling compound type H	-30...+250	fluoropolymer paste

Damping mats (optional)

Damping mats will be used for the gas measurement to reduce acoustic noise influences on the measurement.

Transducer damping mats will be installed below the transducers.

Pipe damping mats will be installed at reflection points, e.g. flange, weld.

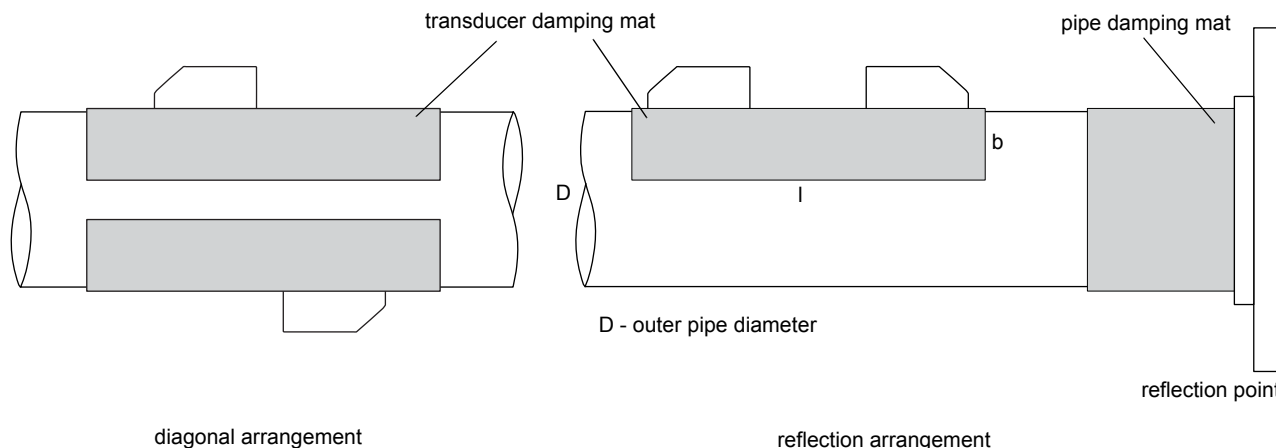

Selection of damping mats

type	description	outer pipe diameter mm	dimensions l x b x h mm	transducer frequency								technical type	ambient temperature °C	remark
				F	G	H	K	M	P	Q				
transducer damping mat														
D	for temporary installation (multiple use), fixed with coupling compound	< 80	450 x 115 x 0.5	-	-	-	-	x	x	x	x	D20S3	-25...+60	
		≥ 80	900 x 230 x 0.5	-	-	-	x	x	-	-	D20S2			
			900 x 230 x 1.3	x	x	x	-	-	-	-	D50S2			
pipe damping mat														
A	for temporary installation (multiple use), fixed with coupling compound	< 300	300 x 115 x 0.5	x	x	x	x	x	x	x	x	A20S4	-25...+60	for quantity see table below
B	self-adhesive	≥ 300	l x 100 x 0.9	x	x	x	x	x	x	-	-	B35R2	-35...+50	l - see table below

Quantity for pipe damping mat - type A

(depending on the outer pipe diameter)

outer pipe diameter D mm	transducer frequency	
	F, G, H	K, M, P, Q
100	12	6
200	24	12
300	32	16

Length of pipe damping mat - type B

(length l depending on transducer frequency and outer pipe diameter)

outer pipe diameter D mm	transducer frequency	
	F, G, H m	K, M, P m
300	12	6
500	32	16
1000	126	63

Connection systems

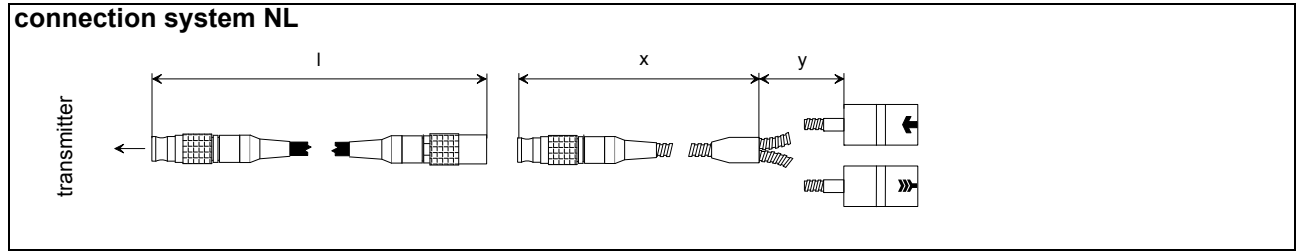

transducer frequency (3d character of transducer order code)		F, G, H, K			M, P			Q			S			
N		x	y	l¹	x	y	l¹	x	y	l¹	x	y	l	
L	cable length	m	2	3	≤ 25	2	2	≤ 25	2	1	≤ 25	1	1	≤ 20

¹ > 25...100 m on request

x, y - transducer cable length

l - max. length of extension cable

Transducer cable

Technical data

		transducer cable	extension cable
type		1699	2551
standard length	m	see table above	5 10
max. length	m	-	see table above
ambient temperature	°C	-55...+200	-25...+80
cable jacket			
material		PTFE	TPE-O
outer diameter	mm	2.9	8
thickness	mm	0.3	6
colour		brown	black
shield		x	x
sheath			
material		stainless steel 304 (1.4301)	-
outer diameter	mm	8	-
remark		-	stainless steel 304 (1.4301) 9 optional

Clamp-on temperature probe (optional)

Technical data

technical type		PT12N	PT12F
design			short response time
type		Pt100	Pt100
connection		4-wire	4-wire
measuring range	°C	-30...+250	-50...+250
accuracy T		$\pm(0.15\text{ °C} + 2 \cdot 10^{-3} \cdot T\text{ [°C] })$ class A	$\pm(0.15\text{ °C} + 2 \cdot 10^{-3} \cdot T\text{ [°C] })$ class A
accuracy ΔT (2x Pt matched according to EN 1434-1)		$\leq 0.1\text{ K}$ (3 K < ΔT < 6 K), more corresponding to EN 1434-1	$\leq 0.1\text{ K}$ (3 K < ΔT < 6 K), more corresponding to EN 1434-1
response time	s	50	8
housing		aluminum	PEEK, stainless steel 304 (1.4301), copper
degree of protection according to IEC/EN 60529		IP66	IP66
weight (without connector)	kg	0.25	0.32
fixation		clamp-on	clamp-on
accessories			
thermal conductivity paste 200 °C		x	x
thermal conductivity foil 250 °C		x	x
plastic protection plate, insulation foam		-	x
dimensions			
length l	mm	15	14
width b	mm	15	30
height h	mm	20	27

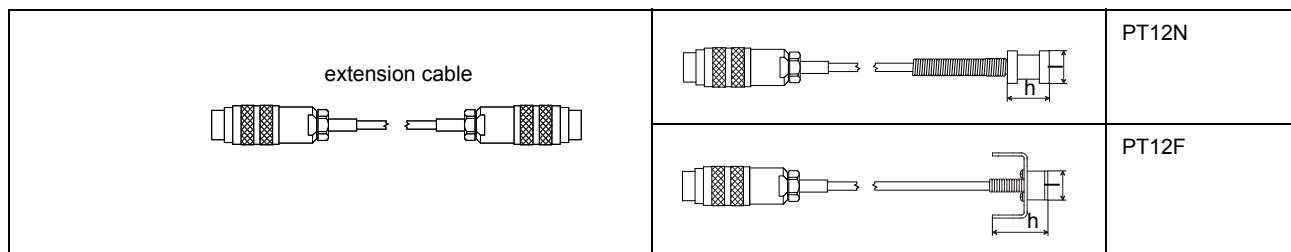

Connection

Temperature probe

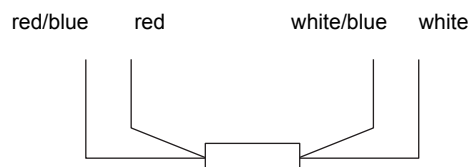

Connector

pin	cable of temperature probe	extension cable
1	white/blue	blue
2	red/blue	grey
3, 4, 5	not connected	
6	red	red
7	white	white
8	not connected	

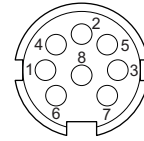

Cable

		cable of temperature probe	extension cable
type		4 x 0.25 mm ² black	LIYCY 8 x 0.14 mm ² grey
standard length	m	3	5/10/25
max. length	m	-	200
cable jacket		PTFE	PVC

Wall thickness measurement (optional)

The pipe wall thickness is an important pipe parameter which has to be determined exactly for a good measurement. However, the pipe wall thickness often is unknown.

The wall thickness probe can be connected to the transmitter instead of the flow transducers and the wall thickness measurement mode is activated automatically.

Acoustic coupling compound is applied to the wall thickness probe which then is placed firmly on the pipe. The wall thickness is displayed and can be stored directly in the transmitter.

Technical data

technical type		DWR1NZ7
measuring range ¹	mm	1...250
resolution	mm	0.01
accuracy		1 % ± 0.1 mm
fluid temperature	°C	-20...+200, short-time peak max. 500
cable		
type		2616
length	m	1.5

¹ The measuring range depends on the attenuation of the ultrasonic signal in the pipe. For strongly attenuating plastics (e.g. PFA, PTFE, PP) the measuring range is smaller.

Cable

type		2616
ambient temperature	°C	<200
cable jacket		
material		FEP
outer diameter	mm	5.1
colour		black
shield		x

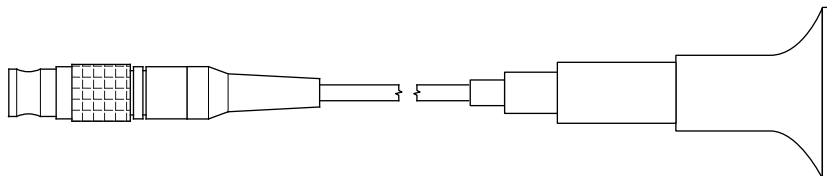

DWR1NZ7



FLEXIM GmbH
Wolfener Str. 36
12681 Berlin
Germany
Tel.: +49 (30) 93 66 76 60
Fax: +49 (30) 93 66 76 80

internet: www.flexim.com
e-mail: info@flexim.com

Subject to change without notification. Errors excepted.
FLUXUS® is a registered trademark of FLEXIM GmbH.

TSFLUXUS_G601V2-1-2EN_Leu, 2017-05-23