

Turbine Flowmeter - Flange, Screw

KTR-550-F Series

SUMMARY

KTR-550-F 은 터빈이 조립 된 기계식 부분과 유량이 표기 되는 전자식 기판이 조합 된 터빈 유량계이며 구동부가 기계식이기 때문에 저온부터 고온까지 유체에 모두 적용이 가능하며 상대적으로 높은 정확도를 가지고 재현성이 우수합니다.

FEATURE

- 1 플랜지 또는 Screw (Male, Female) 타입 선택 가능
- 2 상대적으로 저렴한 가격
- 3 저온부터 고온의 유체까지 적용 범위가 넓음
- 4 액체, 기체 등 다양한 유체에 적용 가능



KTR-550-F-F



KTR-550-F-T

MODEL CODE

KTR-550	-	□	-	□	-	□	Specification
		S					DC 4-20 mA
		MF					Battery 내장 DC 24 V(2-Wire) Indicator & Totalizer DC 4-20 mA
		F					AC 110/220 V (50~60) Hz DC 24 V(4-Wire) Indicator & Totalizer DC 4-20 mA, Pulse
				F			Flange
				T			Screw (Male, Female)
						Ex	Ex d IIC T5 (ex-proof)

STANDARD SPECIFICATION

Connection	KS/JIS/ASME/DIN Std. Flange
Size	6A(1/8") ~ 250A(10")
Measured Fluid	Gas and Liquid
Flow Range	Water : (0.04 ~ 1,000) m ³ /h Air : (0.7 ~ 500) Nm ³ /h
Temp. range	-20 °C ~ 120 °C (Option. -200 °C ~ 450 °C)
Press. range	350 kgf/cm ² .G (1B 이하) 60 kgf/cm ² .G (1-1/2B 이상)
Monitor	3-1/2 LCD (Flow rate) 7 Digit LCD (Integration)
Power	3.6 V Alkaline Battery DC 24 V (2-Wire, 4-Wire) AC 110/220 V 60 Hz
Output	DC 4-20 mA, Pulse Turbine Pulse. RS-485 Contact 2P High, Low
Accuracy	±0.5 % F.S (Option ±0.2 % F.S)

■ FLOW RANGES & DIMENSIONS

Connector Size		Flow ranges	
		Water(m ³ /h)	Air(Nm ³ /h)
6A	1/8 B	0.04 – 0.4	–
8A	1/4 B	0.06 – 0.6	–
10A	3/8 B	0.12 – 1.2	–
15A	1/2 B	0.3 – 4	0.7 – 7
20A	3/4 B	0.6 – 6	–
25A	1 B	0.6 – 10	4 – 40
32A	1-1/4 B	1.5 – 15	–
40A	1-1/2 B	1.5 – 20	8 – 80
50A	2 B	2 – 40	16 – 160
65A	2-1/2 B	5 – 60	–
80A	3 B	5 – 100	34 – 340
100A	4 B	15 – 200	50 – 500
125A	5 B	25 – 250	–
150A	6 B	30 – 300	–
200A	8 B	50 – 500	–
250A	10 B	100 – 1000	–

■ STANDARD MATERIAL

No.	Description	Material	
		Normal	Option
1	Body	304SS	316SS
2	Rotor	CD4MCH	
3	Rotor shaft	TUNGSTEN CARBIDE	316LSS
4	Rotor supports	304SS	316SS
5	Bushing	TUNGSTEN CARBIDE	HIGH DENSITY PLASTIC
6	Thrust ball	TUNGSTEN CARBIDE	316SS
7	Retaining ring	304SS	316SS

√ 기체의 압력 1 atm · 20 °C 일 때이며 P kgf / cm².G에는 본 표의 수치에 $\sqrt{P + 1}$ 을 곱해야 함.

■ DRAWING

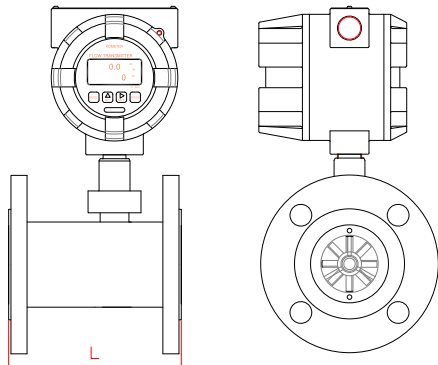

■ STRUCTURAL DRAWING

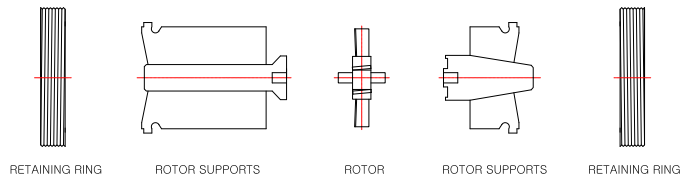

■ DIMENSIONS

Connector Size	L (mm)	Connector Size	L (mm)
10A	150	65A	200
15A	150	80A	200
20A	150	100A	220
25A	150	125A	250
32A	150	150A	300
40A	150	200A	360
50A	150	250A	400

√ Length 주문제작 가능함.

■ STRAINER

Turbine size	Strainer mesh	Clearance
3/8"	60	0.0092
1/2"	60	0.0092
1"	60	0.0092
1-1/2"	40	0.0340
2"	30	0.0650
2-1/2"	30	0.0650
3"	20	0.0900
4"	20	0.0900
6"	10	0.1875
8"	8	0.1875

KM-1401TBF-KR